

Inflectional Case Assignment in Cebuano

Paul Llido
 Department of Languages and Literature
 College of Arts and Sciences
 University of San Carlos
 Cebu City
pcllido@usc.edu.ph
pllideau@yahoo.com

ABSTRACT

The paper will explore the application of Falk 1997 to Cebuano (CEB) case marking. It will explain that the internal argument canonical structure of the verb grammar is controlled by the system of inflectional affixes. It will also prove that the inflectional affixes assign case and not the verb base.

As a parallel to theta roles, the assignment of internal and external case to the Topics/Foci depends on the case compositionality of the affixes which in turn matches their theta role compositionality. The assignment of external case is shown to trigger an ergative interpretation. Grammaticality case requirements will also be covered as well as the confluence of verb base selectional restrictions with the triggering case affixes.

GB/PP and some Minimalism will be used to analyze the case projection of the arguments with some examples using LFG analysis.

Primitives of Sentential Grammaticality

To build a CEB sentence at least two lexemes are required¹. The two lexemes may all be substantives as in (1a).

1a.	* bunga	manga
	‘fruit’	‘mango’
	[fruit]	[mango]

One of the two substantives may be a modifier² as in (1b).

2a.	* bun–ug	manga
	‘bruised ³ ’	‘mango’
	[bruised]	[mango]

To make the sentence grammatical at least one of the lexemes must be marked by [ang] as in (3a) or (3b).

¹ Substantives, however, denoting natural climatic phenomena do not need another substantive to compose a sentence.

² Cebuano modifiers pass a morphological modifier test that other substantives do not. I will not discuss this in this paper.

³ ‘bruised’ in the sense of having several softened spots probably due to being bumped around so much while being transported from the farm to the wet market.

equational sentence structure is unmarked. It is a base structure for CEB. Verbalized sentences are marked and can easily be converted into equational sentences.

The Case of Inflectional Affixes

Prefixing the V-affix [Xa-]⁶ to the nominal on the left totally changes the semantico-syntactic landscape of (3a) as shown in (6a). We now have a verb argument structure. (6a) and (6b) show the use of the [MAN-]⁷ and [MA-]⁸ prefix respectively. I show (6b) where the stem is a modifier and not a substantive for purposes of comparison.

- | | | | | |
|-----|--------|------------------------------|-----|-----------|
| 6a. | man- | bunga | ang | manga |
| | | ‘fruit’ | | ‘mango’ |
| | [Vaff] | [fruit] | THZ | [mango] |
| | | bears-fruit | | the-mango |
| | | ‘the mango will bear fruits’ | | |
| | | | | |
| 6b. | (ma-) | bun-ug ⁹ | ang | manga. |
| | | ‘bruised’ | | ‘mango’ |
| | [Maff] | [bruised] | THZ | [mango] |
| | | bruised | | the-mango |
| | | ‘the mango is bruised’ | | |

Before we continue though, let us check whether any of the lexemic elements in (6a) and (6b) continue to guarantee grammaticality in (7a) and (7b).

- | | | | | |
|-----|--------|---------|-----|---------|
| 7a. | *man- | bunga | | manga |
| | | ‘fruit’ | | ‘mango’ |
| | [Vaff] | [fruit] | [Ø] | [mango] |

It seems that the one THZ grammaticalization rule still applies in (7a).

In (6a), [MAN-], in particular, changes the argument structure from an order of non-subcategorization of syntactic equationality where [α] and [β] stand on the same syntactic level as coequal nominals in an appositive series in (5a) to a subcategorization hierarchy where [α] now is the result and/or actualization of an action and ability of [β] as shown in (8a). The change to a subcategorization system from (5a) is also paralleled by a change in the hierarchy of semantic roles as seen in the thematic grid of (8b) with the acquisition of an agent (AGT) theta role.

- | | | |
|-----|------------|--------------------------|
| 8a. | [mamunga]: | V, (SMP ¹⁰) |
| 8b. | [mamunga]: | V, (AGT) |

⁶ In the affix abstraction [Xa-], the lexeme X represents the two instantiations [ma-] and [na-] for the [MA-] V-affix class.

⁷ [MAN-] provokes a morphophonemic change in the first consonant of the stem and at Spell-Out this sound would differ depending on the consonant class of the first consonant.

⁸ [MA-] has a certain syncretism. It is a V-affix as well as noun class modifier prefix.

⁹ The [MA-] prefix here is a modifying prefix and possibly a portmanteau morpheme.

¹⁰ SMP means Substantive and Modifier Phrase

The change in valence from a logical identity structure to a verb argument structure is better seen when we juxtapose the two examples (9a) and (9b).

9a.	anak	si	Maria	ni	Pedro	ug	ni	Marta.
	‘child’	‘Mary’			‘Peter’			‘Marta’
	[child]	THZ	[Mary]	POSS	[Peter]	CONJ	POSS	[Martha]
	REF1		REF2		subREF1			subREF1
	child		Mary	of-Pedro		and		of-Martha
	‘Mary (is) the-offspring/child/daughter of-Peter and of-Martha’							
9b.	[MAN–] anak	si	Maria	ni	Pedro	ug	ni	Marta
	‘child’	‘Mary’	‘Mary’		‘Peter’			‘Martha’
	[Vaff]	[child] NOM	[Mary]	ACC	[Peter]	CONJ	ACC	[Martha]
		THM	AGT		PAT			PAT
	factual-to-give-birth		Mary	to-Pedro		and		to-Mary
	‘Mary will-give-birth to-Peter and Martha’							

(9a) is an equational sentence while (9b) is the same sentence with a verbalizing prefix. The [si] in (9a) case-marks and also thematizes [Maria]. The [ni] in (9a) case marks the proper nouns [Pedro] and [Marta] with possessive case (POSS). There is some dynamic scrambling here and [Pedro] and [Maria] actually depend on [anak]. The possessive case (POSS) as well as the oblique case (OBL) is a universal property of nouns or nominals and it is not surprising that in an equational structure these cases occur. The important point to remember here is that in an equational set-up and in the confluence of two nominals each with a potentiality to mark POSS and OBL that the old information [anak] is the natural referent of [Pedro] and [Marta]. The referents of the equational sentence are clearly shown in referent one (REF1) and referent two (REF2). The two subREFs of REF1 are also shown.

Except for [ug]¹¹ which maintains the same [CONJ] lexical category, all the other lexemes change CASE and THETA ROLE in (9b). [anak] now becomes the theme of the abilitative verbalizing sense of [MAN–] while [Maria] becomes the agent of that abilitative action; and [Pedro] and [Marta] become the patients. Although, externally there seems to be no morphological change in the case markers, there is a change in theta role. This must occasion a change in case-marking because Theta Roles are the interpretation of LF on the semantic side while Case-Marking is the interpretation of PF on the morphophonological side (Falk 1997). This phenomena is widespread in CEB and the only morphological explanation for the concatenation of changes seems to be the affixation by the verbalizing prefix (in this case the prefix [MAN–]).

The change, moreover, does not seem to be just a mere supplanting of the extant noun class possessive cases. Rather, the selectional restrictions of the participant nouns in their natural semantic entailments continue. A native speaker would still expect that [anak] and [Maria] together would entail nominals with [+human] features. This will become a relevant in our discussion later on.

¹¹ [ug] also undergoes categorical change but not in this context. I leave this out of the discussion..

What about the stem?

The analysis above raises another important question. With the verbalizing prefix being an agglutinate and a bound morpheme, we may come to think that it now forms a solid base together with the stem—this would be [anak] in (9b)—and lose its lexemic independence and that the stem together with the V-affix form the verb and that both together act as a verb and now control the argument structure. This doesn't seem to be the case at all as shown in (10a) and (10b).

- 10a. mang– unsa ang manga?
 ‘what’
 [Vaff] [what] THZ [mango]
 ‘what-be-able-to-do the-mango?’
 ‘what will the mango be able to do?’
- 10b. mang– unsa si Maria ni Pedro ug ni Marta?
 ‘what’ ‘Mary’ ‘Peter’ ‘Martha’
 [Vaff] [what] NOM [Mary] ACC [Peter] CONJ ACC [Marta]
 what-will Mary be-able-to-do of-which-Peter and of-which-Marta will-be the-result

If the stem is removed and replaced by a CEB [WH] which is a [–SA–], the same spread of argument structure changes holds. This can only mean that the verbalized stem is not lexemically part of the verb and that it should somehow intuitively enter into the argument structure as an argument and not as verb head because the [–SA–] replacement should have occasioned a change in the landscape of theta roles if it were the verb head together with [MAN–] but it doesn't.

Bringing this observation forward, this, in effect, means that the verb affix [MAN–] is the only inflectional morpheme left that we can see that exerts subcategorization and theta control over the other arguments and intuitively the stem. [MAN–] (and any other V-affix) then must be a head and a verb case and theta –assignor because it is the only morpheme that remaining that can identify the arguments at a morphophonological level as evidenced and matched by the change in theta assignment. It is interesting to note—and this is quoted by (Falk 1997)—that Aoun, as quoted in turn by Chomsky (1981), had already observed the parallelism between theta roles and case and that accordingly, in this parallelism, the theta role is a property of the LF component while case is a property of the PF-component.

Of course, CEB nouns and modifiers, too, assign NOM and GEN cases in a noun semantico-syntactic structure (which is proper to attribution) but this is a universal property of noun class lexemes. The point of [MAN–] (or any V-affix for that matter) being a case assignor refers to case assignment for arguments that are proper of verb classes like NOM, ACC or DAT.

On a global inflectional perspective, this seems to point to a situation where we have two orders of grammatical structures as seen in the use of the [si] and [ni] case markers. The first order being that of equational sentences that project an attributive semantico-syntactic structure. There is one head substantive or modifier and the other substantive or modifier adds new attributive information about it as in the equational sentences in (4a)

and (4b) where [si] marks for NOM case and [ni] marks for GEN case. The second order of grammatical sentences pertains to verb sentences that have valence. In the latter instance, [si] marks for NOM case while [ni] marks for ACC case. I am not entirely content with labeling the [si] as NOM case-marking in equational sentences in comparison to labeling [si] as NOM case-marking in verbalized sentences because the parallel theta role in the former cannot be said to be equated to the parallel AGT theta role of the latter. For now, I will loosely label the former NOM case and sometimes REF case.

As for the status of the V-affix as a case and theta –assignor, it is my contention given the evidence that [MAN–] upon affixation exerts case and theta control on its arguments and that technically it itself alone–excluding the stem–is the verb and will refer to it as such from now on.

Does the stem get case assignment?

It does not seem difficult to intuit that the stem receives some kind of case and thereby a theta role. After all, structurally this can be explained by government in GB/PP. Discoursewise, native CEB speakers can infer that the verbalized sentence is really about the sense of the stem whatever it be. This makes me conclude that it does have some kind of theta role akin to Theme (THM).

Let me try proving this point by positing that the stem does have case and see whether it will survive. Let me posit that in a parallel manner the stem gets assigned a Theme (THM) theta role. The argument structure in (8a) and (8b) should now look like (10c). THM, AGT, PAT are theta roles that mean theme, agent and patient.

$$10c. \quad * [MAN-] : \quad V, \quad \{ \text{SMP}_{\text{stem}}, \text{SMP}_1, \quad ((\text{DP}) \parallel (\text{SMP}_2)) \} \\ \text{THM}, \quad \text{AGT}, \quad ((\text{PAT}) \parallel (\text{THM}))$$

(10c) immediately gets snagged in the Theta Criterion and becomes ungrammatical.

Please take note that (10c) is exemplified in sentence (9b) but with an optional logical-or with a DP phrasal category for Determiner Phrase. On closer look though, SMP_2 — [Pedro] in (9b)—seems to be always taxonomically a subset of the superset SMP_{stem} — [anak] ‘child’ in (9b). The same thing would happen if we extend (6a) into (10ca).

10ca.	ma–	munga	ang	manga	[_{DP} ug mga	gagmayng	manga]
		‘fruit’		‘mango’		‘small’	‘mango’
	[Vaff]	[fruit]	THZ	[mango]	nDEF PLU	[small]	[mangoes]
		SMP		SMP ₁	DP		
		THM		AGT	subTHM		
		THC		(NOM) ¹²	(ACC) ¹³		
		factual-bear-fruit		the-mango		small-mangoes	
		‘the-mango-tree will-bear		small-mangoes’			

¹² Not externalized because [manga] is not a proper noun.

¹³ -idem-

nDEF means indefinitizer and PLU means pluralizer. In (10ca), the same concept class subsumption occurs. I resolve this issue by categorizing the potentially conflicting theme theta role of the DP or the SMP₂ as a subtheme or subTHM.

Another way to prove that the stem does have case assigned to it is whether the slot can be occupied by a personal pronoun. This will be shown shortly in a related discussion.

Does the interrogative [unsa] tell us something about the stem?

[unsa] is the interrogative that is used to replace any non-proper noun or any non-nominative-personal-pronoun or any substantive that does not denote time or place. In fact, I can replace [anak] in (9a) and transform the sentence into an interrogative in (10d).

10d.	unsa	si	Maria	ni	Pedro	ug	ni	Marta?
	'what'		'Mary'		'Peter'			'Marta'
	[what]	THZ	[Mary]	POSS	[Peter]	CONJ	POSS	[Martha]
	what (is)		Mary	of-Peter	and		of-Martha?	
	'how is Mary related to Peter?'							

The fact that any CEB stem verbalized by a V-affix is replaceable by [unsa] can only mean on a lexical level that the stem is a substantive or a noun class lexeme and its visibility on a syntactic level requires it to fulfill the Case Filter which means that it should get a case assignment. Unfortunately, the case assignment is not externalized because of another rule that says that only proper nouns and personal pronouns get externally marked.

Where does the stem lexically insert itself into the sentence?

The phrasal category of the stem which is SMP should be projected as a complement of VP. Being an internal argument of the verb, this would be the best interface point. But this is not enough. The stem should unite morphologically with the V-affix bound morpheme at some point in time. There will have to be movement into the head of VP by the stem to fulfill morphological composition, that is, after case assignment in (10e). This is not entirely a satisfactory explanation. There is sufficient evidence from (Haspelmath 2002) in his discussion of free and bound forms that [MAN-] in our discussion is not strictly morphologically a bound form. Among many reasons, it is prosodically independent and it is interruptible at the morphemic boundary.

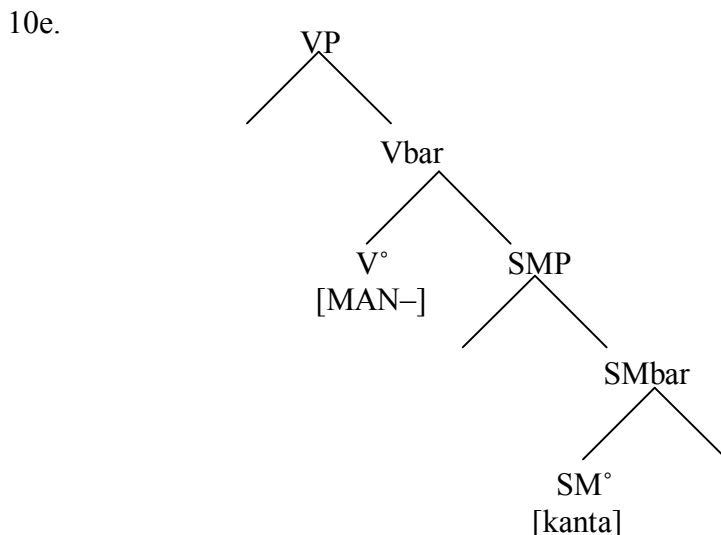

To further highlight this lexemic independence of the stem, I write down in (10f), a partial list of the representatives of CEB affix classes to graphically depict the lexemic integrity of [kanta] despite affixation by the V-affixes. The gloss of ‘kanta’ does not change.

- | | | | |
|------|--|---|--------------|
| 10f. | [MAN-]
[MA-]
[MO-]
[MAKA-]
[MAG-]
[HING-]
[-(H)AN]
[-(H)ON] | } | kanta ‘song’ |
|------|--|---|--------------|

Intensionally, the V-affixes seem to be closer to action modes of doing/becoming the stem noun. But let us try to have a glimpse of their topology of arguments and features. I will build the subcategorization, syntactic function, theta roles and the case-mark (if the noun at that position is a proper noun) for these affixes in this paper (10g). Please note that CEB grammar allows some scrambling of arguments in certain selectional contexts but this will not be discussed here

- | | | | |
|------|---------|--------------|--|
| 10g. | [MAN-] | kanta ‘song’ | { SMP, SMP, (DP) }
SUBJ OBJ
THM AGT subTHM ¹⁴
[si] |
| | [MO-] | kanta ‘song’ | { SMP, SMP, (DP) }
SUBJ OBJ
THM AGT subTHM
[si] |
| | [MAKA-] | kanta ‘song’ | { SMP, SMP, (DP) }
SUBJ OBJ
THM AGT subTHM
[si] |
| | [MAG-] | kanta ‘song’ | { SMP, SMP, (DP) }
SUBJ OBJ
THM AGT subTHM
[si] |
| | [HING-] | kanta ‘song’ | { SMP, SMP, (DP) }
SUBJ OBJ
THM AGT subTHM
[si] |

¹⁴ The subTHM is semantically and taxonomically a subsumption of the THM.

[MA-]	kanta ‘song’	{ SMP, THM	SMP, SUBJ subTHM	SMP } OBJ AGT [ni]
[-(H)AN]	kanta ‘song’	{ SMP, THM	SMP, SUBJ LOC [si]	SMP, (DP) } OBJ AGT subTHM [ni]
[-(H)ON]	kanta ‘song’	{ SMP, THM	SMP, OBJ AGT [ni]	SMP } SUBJ subTHM

The Different Inflectional Orders of Cases

Each V-affix above is a lexeme that represents a class of related V-affixes. Each class imposes its own argument structure on the clause. In the case of [MAN-], [MO-], [MAKA-], [MAG-], [HING-], the proper noun having the AGT theta role is externally marked with the [si] NOM case marker. In the case of [MA-], [-(H)AN], [-(H)ON], the proper noun having the AGT theta role is marked with the [ni] ACC case marker. If we then take the AGT role as the point of reference for classifying the V-affixes, it will appear that there are three orders of case assignment:

- first, where the V-affix assigns NOM case to the SMP with an AGT theta role;
- two, where the V-affix assigns ACC case to the SMP with an AGT theta role;
- third, where the V-affix assigns no case and no theta role.

Thus, we are dealing here with not only one case assignment systems but three case assignment systems.

The Interplay between Semantic Entailment and Case

The noun [kanta] ‘song’ in (10g) semantically entails [singer], [the person to/for whom the singer sings], [specific kind of song], [place where one sings]. These entailments are imaginable in a CEB possible world semantic system. Any substantive or modifier in the language—for this matter—will build this network of related concepts. What is interesting to note is that the V-affixes—each class in turn—order these entailments into case and theta canons. Each V-affix class is unique but they can be categorized according to certain patterns. One pattern seems to be categorized according to the way it parametrizes. The [MO-] and [MAKA-] classes are what I call matrix-type classes. They vary across an x- and y- axes: grammatical time (and aspect) and voice. The rest like [MAG-], [MAN-], [MAKIG-], [MA-], etc are what I call paradigm classes. They vary only according to one axis: grammatical time (aspect).

The pattern, though, that interests us most is the pattern of case-marking. One group [MA-], [-(H)AN], [-(H)ON], [-I] case-marks the proper nouns with theta AGT with ACC case. While the other group marks the same nouns with NOM case.

The Confluence of Discourse Thematization and Case-Marking

It also appears that on a morphological level, thematization which seems to be part of a discourse grammar conflows with case. Personal pronouns and proper names when marked with case do not need to be thematized. Non-personal pronouns and non-proper nouns need to be thematized with [ang] for the sentence to be grammatical. (7a) demonstrates this clearly. When the latter are thematized, they do not need to be case-marked.

The Issue of Animacy

CEB case on substantives and modifiers are marked according to a certain paradigm of animacy. Falk 1997 points out that this seems to be the pattern for cases universally, specially accusative cases in many language families. Of course, in CEB, inherent case-marking is exemplified in all the different cases for all personal pronouns and for proper nouns.

Personal pronouns are inherently case-marked. The lexemes are in themselves distinct as to case form as in (11a), (11b), (11c) and (11d).

- 11a. [AKO] = {[ako], [ikaw], [ka], [siya], [kita], [kami], [kamo], [sila]}
- 11b. [AKO?] = {[ako?], [imu], [iya], [ato?], [amo?], [inyo], [ila]}
- 11c. [NAKO?]= { [nako?], [nimo], [niya], [nato?], [namo?], [ninyo], [nila] }
- 11d. [KANAKO?] = [kanako?], {kanimu}, [kaniya], [kanato?], [kanamo?], [kaninyo], [kanila]}

(11a) is inherently marked for NOM case. This case appears in sentences triggered by V-affixes. (11b) is a proclitic GEN (genitive) case. I am using the proclitic form to represent the class of enclitic GEN pronouns too. The only difference is their distribution which for enclitic pronouns is located after the nominal group as opposed to the proclitic forms that occur before the nominal group. The GEN case appears very often in equational sentences as a function of the semantico-syntactic structure of logical identity. (11c) is likewise inherently marked for ACC (accusative case). With some verb affix distributions, (11c) marks for DAT (dative case).

The next rung in the hierarchy of animacy seems to be personal names or proper nouns. These names are externally case-marked by [si] for NOM and [ni] ACC (accusative case) as in (11d) and (11e).

11d.	Gi-	sagpa	si	Pedro	ni	Maria
		‘slap’		‘Peter’		‘Maria’
	[Vaff]	[slap]	NOM	[Peter]	ACC	[Mary]
		slapped	Peter		by-Mary	
		‘Peter was-slapped by-Mary’				

11e.	Sagpa	–on	si	Pedro	ni	Maria
	‘slap’			‘Peter’		‘Mary’
	[slap]	[Vaff]	NOM	[Peter]	ACC	[Mary]
	will-be-slapped		Peter		by-Mary	
	‘Peter will-be-slapped by-Mary’					

All other substantives and modifiers (that is, non–personal pronouns and non personal names) have abstract case but are not marked for external case. This assumption is proven in that these lexemes occupy the same nodes occupied by the case–marked lexemes as in (11f) and (11g).

11f.	Mo–	kanta	ang	langgam	ug	awit
		‘song’		‘bird’		‘song’
	[Vaff]	[song]	THZ	[bird]	DEF	[song]
		will-sing		bird	a-song	
	‘the-bird will-sing a-song’					

11fl.	[MO–]:	V,	{ SMP,	SMP,	(DP ¹⁵) }
			THM	AGT	(ACC)

11g.	Mo–	kanta	ang	langgam	sa	awit
		‘song’		‘bird’		‘song’
	[Vaff]	[song]	THZ	[bird]	DEF	[song]
		will-sing		bird	the-song	
	‘the-bird will-sing the-song’					

Both (11f) and (11g) have the same argument structure in (11fl). The subcategorization slots are occupied by the same nominal categories and the verb affix triggers the same theta roles. [ug] is an indefinitizer and [sa] is a definitizer.

The Case Filter and the Theta Criterion

Phonologically overt CEB substantives and modifiers in A-positions get assigned case following the Case Filter. These A-positions, likewise, get a theta role through the Theta Criterion. One way to check whether an A-position can be assigned case is to put a personal pronoun in the same position as in (12x). Since personal pronouns have inherent case, landing them at a position that is assigned case should produce a grammatical sentence. When personal pronouns inhabit the V-affix-stem positions they may take NOM or GEN cases but I am labeling them as THC for now because deciphering which particular case a position is assigned belongs to a full study of the topology of V-affixes which is not directly the focus of this paper.

12a.	mo–	kanta	ang	bata
		‘song’		‘child’
	[Vaff]	[song]	THZ	[child]
		THC	NOM	
		will-sing		the-child
	‘the-child will-sing’			

12aa.	mo–	kanta	siya
		‘song’	3 rd pers
	[Vaff]	[song]	[he/she]
		THC	NOM
	‘he/she will-sing’		

¹⁵ DP means Determiner Phrase

- 12b. kanta –hon ni Maria ang rock
 ‘song’ ‘Mary’ ‘rock music’
 [song] [Vaff] [Mary] THZ [rock]
 THC ACC NOM
 will-be-sung by-Mary the-rock-music
 ‘rock-music will-be-sung by-Mary’
- 12bb. kanta –hon niya ang rock
 ‘song’ 3rdpers ‘rock music’
 [song] [Vaff] [him/her] THZ [rock]
 THC ACC NOM
 ‘rock-music will-be-sung by-him/her’
- 12c. mag– kamu-kamu mu
 2ndplu 2ndplu
 [Vaff] [you] [you]
 THC NOM
 ‘you-exclusive will-do-things-your-own-excluding-us-reduplicated’
- 12d. ato –on nato ang kotsi
 1stpers .plu 3rdpers.plu ‘car’
 [Vaff] [ours] THZ [car]
 THC GEN NOM
 ‘let-the-car be-taken-and-possessed by-us’

The Structural Representation of Case Assignment

Under GB/PP, the V-affix is lexically inserted at the head of VP. This will allow it to govern and theta-mark any noun occupying the head of SMP. It is easy to conceive the thematic marking with the THM (Theme) theta role. The case assigned would not fall into any standard case categories for this position. I will call it THC for Thematic Case for now. Since SMP is the complement of VP and [bunga] interfaces at the head of the SMP, it will inherit the THC case and will also get assigned the THM theta role.

(13a), though, might produce a potentially problematic sentence at this stage because non-pronoun and non-personal CEB substantives and modifiers might be too far away from the case assignor V-affix. [bunga] gets a case assignment because of adjacency but [manga] might not. I found no evidence, though, to support the existence of barriers in structural case assignment. At the level of the argument structure the SMs would need case and at the discourse level there must be at least one Thematized SM or one SM assigned with NOM case. The sentence used in (13a) has been displayed in (9b).

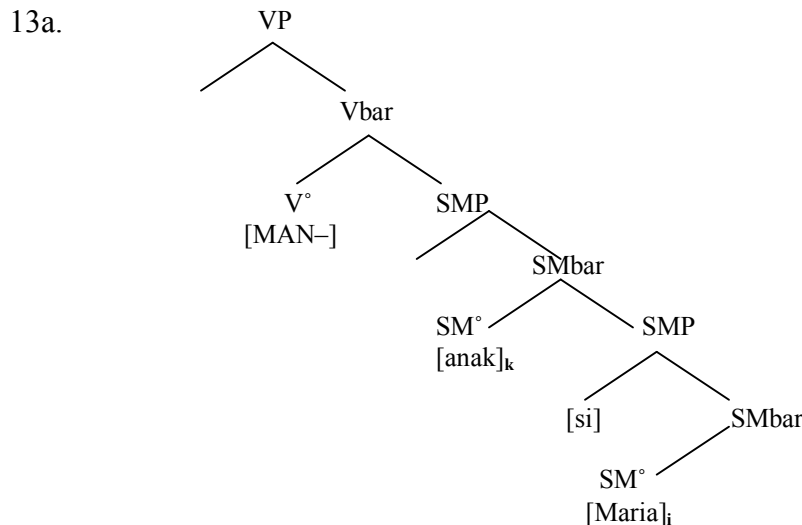

The Minimalist version of this structure posits 5 functional categories: two Thematization Phrases (ThzP); an Agreement Phrase for the Subject (AgrSP); an Agreement Phrase for the Object (AgrOP); a Tense Phrase (TP) which is the functional category that checks for tense-aspect features.

The V-affix (*q*) inserts itself first at VP with features for tense-aspect like present and past; as well as its unique argument structure in a subcat grid; and the theta roles to be assigned in a thematic grid. The V-affix ([MAN-]) subsequently moves from the head position of VP to the head position of TP (*q1*) and checks for tense-aspect (say past tense). Then it moves to the head position of AgrOP (*q2*) and checks the subcat grid for an OBJ slot and a case slot (in the case of [MAN-] for NOM case) and the thematic grid for a corresponding theta role (that is, AGT theta role for the substantive). It moves next to the head position of AgrSP (*q3*) and checks the subcat grid for a SUBJ slot, a case slot for NOM case and the thematic grid for the corresponding PAT theta role¹⁶. It finally lands at the head position of Thematization Phrase1 (*q4*). Since [MAN-] is a bound morpheme, it is unstable at this point but already fully phonologically interpretable. It waits for the first available noun to bind to (one possible interpretation).

The substantives or modifiers at the interface level do not get assigned any case nor tense nor thematization. SMP1 (*y*) is the potential stem of the V-affix. Being the first stem around, it will necessarily bind with the V-affix. It will move to the specifier position of VP (*y1*) to get checked for THC case. It next moves afterward straight to the THP1 head position as a morpheme of (*q4*), that is as (*y2*). There is serious reason to believe that the THC is actually some type of noun-based case like NOM.referent or GEN that is processed at a derivational level but this will not be covered in this paper.

SMP2 (*p*) then moves to the specifier position of AgrSP (*p1*) the head of which has been seeded earlier with NOM case by the V-affix [MAN-]. SMP3 (*d*) moves next to the specifier position of AgrOP (*d1*) the head of which was earlier seeded with ACC case by [MAN-].

If the movement stops at this point, the sentence will become ungrammatical because sentential rule that requires at least one [ang]-thematized nominal has not yet been fulfilled. [MAN-] though occupying the head position of ThP1 is not [ang]-marked. This means the nominal occupying the head position of AgrSP will still have to move to the head position of ThP2 (*p2*) and be correspondingly marked by [ang] in specifier position if it is not a proper noun. It also appears that the lower ThP2 needs to be thema-occupied first¹⁷.

¹⁶ I mentioned earlier that there is a certain scrambling of the order of the SUBJ and OBJ nominals in CEB. When the NOM marked nominal (and AGT theta role marked) occurs first, the ACC marked nominal becomes optional but when the ACC nominal (and PAT marked theta role is marked) occurs first, the NOM marked nominal is obligatory. This could very well be taken care of by one AgrP structure but I will instantiate the two agreement phrases to simplify the discussion.

¹⁷ I am introducing here some Theme-Rheme discourse marking.

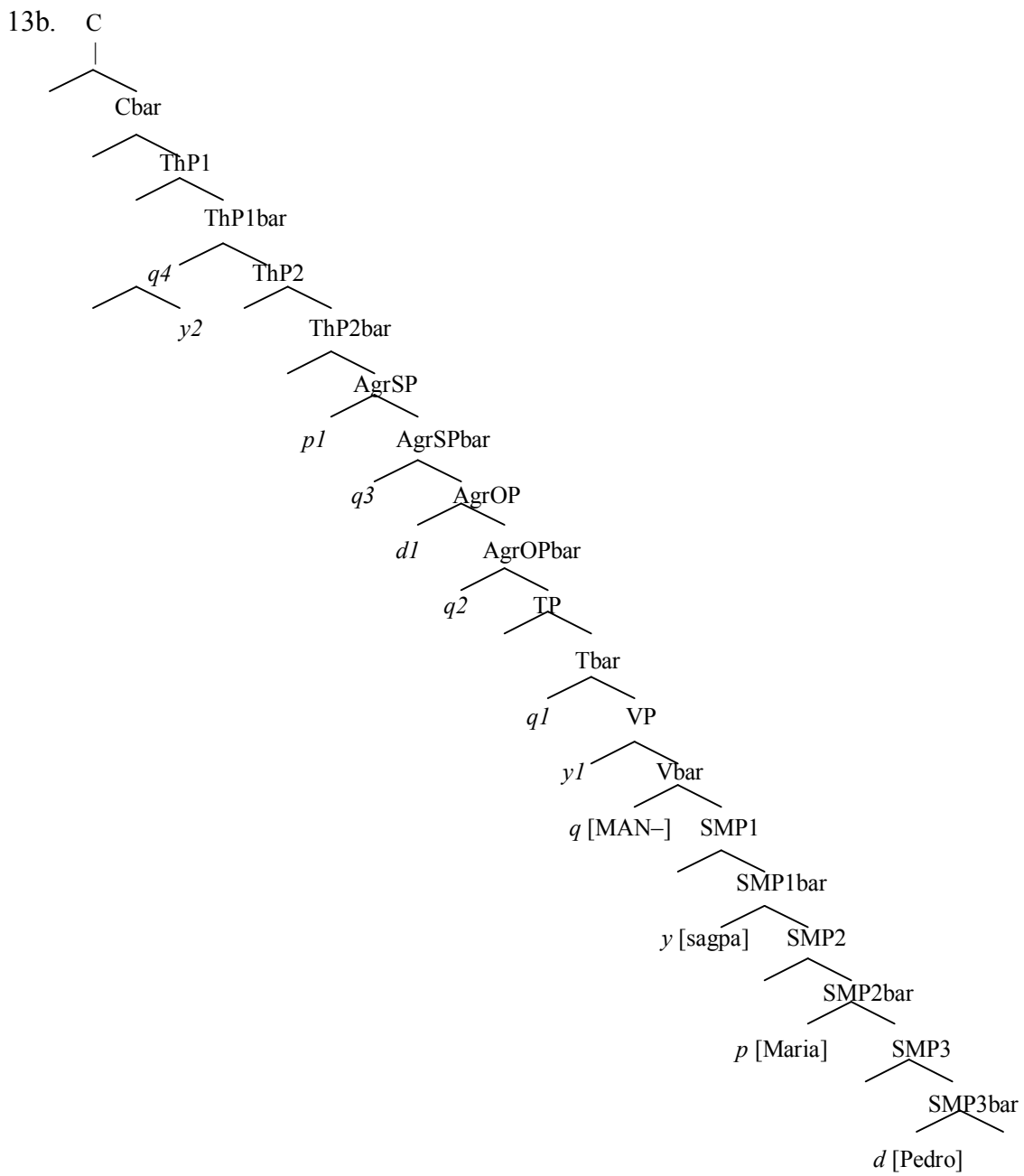

BIBLIOGRAPHY

- Bresnan, Joan (2001). *Lexical-Functional Syntax*. Blackwell Publishers.
- Chomsky, Noam (1981a). *Lectures on Government and Binding*. Dordrecht, Foris.
- Chomsky, Noam (1986). *Barriers*. Cambridge, Massachusetts, MIT Press.
- De La Serna, Lorenzo (1994). *Exploring the Cebuano Language*. Solo Printing and Graphic Designs, Cagayan De Oro City.
- Dowty, David; Wall, Robert; Peters, Stanley (1981). *Introduction to Montague Semantics*. D Reidel Publishing Company.
- Falk, Yehuda (1991). "Case: Abstract and Morphological." *Linguistics* 29: 197-230.
- Falk, Yehuda (1997). *Case Typology and Case Theory*. Department of English, The Hebrew University of Jerusalem. Online publication.
- Fillmore, Charles (1968). "A Case for Case." In Emmon Bach and Robert Harms, eds, *Universals in Linguistic Theory*. New York: Holt Rinehart and Winston. 1-88.
- Haegeman, Liliane (1994). *Introduction to Government and Binding Theory*. 2nd Edition. Blackwell Publishers UK.
- Haspelmath, Martin (2002). *Understanding Morphology*. Understanding Language Series: Arnold Publishers, London.
- Trosdal, Mimi (1992). *Formal-Functional Grammar of the Cebuano Language (with a functionally labeled English Cebuano Vocabulary)*. Salvador & Pilar Sala Foundation Inc, Cebu City.
- Veenstra, Mettina Jolanda Arnoldina (1998). *Formalizing the Minimalist Program*. (doctoral dissertation) University of Groningen.



The preceding document was presented at the Tenth International Conference on Austronesian Linguistics (10-ICAL). To properly reference this work, please use the following format:

<LastName>, <FirstName>. 2006. <PaperTitle>. Paper presented at Tenth International Conference on Austronesian Linguistics. 17-20 January 2006. Puerto Princesa City, Palawan, Philippines.
<http://www.sil.org/asia/philippines/ical/papers.html>

For other papers that were presented at 10-ICAL, please visit <http://www.sil.org/asia/philippines/ical/papers.html>.